

Hello 100 – Sink Mixer



Product

86799.7.01

Description

"Hello 100" Chrome plated deck mounted DUEL SENSOR electronic water sink mixer with multi-function button and 360° rotated swivel spout, manual operated handle lever, DC powered.

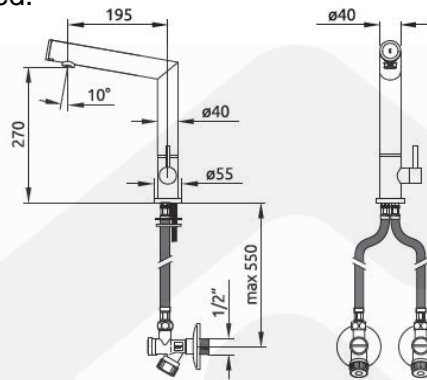

On-Off Sensor
Water starts flowing as soon as someone approaches the tap from the front; useful for dispensing water or filling containers.



Eco-Flow Sensor
It detects the presence of objects or people approaching from below, making it ideal for washing hands or objects.

Finish options:



Remarks:

- Electronic tap with DMP Dual Sensor technology
- Sleek and sharp line design
- Tempered glass on-off front sensor
- Solenoid valve built into the tap body
- Sensor beam adjustable from 5 to 20 cm
- Ceramic disk mixer
- Anti-limescale tap aerator
- Manual function to be activated in case of depleted batteries
- Miniature components, integrated in the chrome-plated brass body
- Anti-flooding automatic stop after 3 minutes
- Solenoid valve with triple stainless steel anti-contaminant filter
- Connections with stainless steel filter and built-in non return valves
- 360° rotating spout, ideal for island kitchens
- Colours with special pigments, certified for food use
- 1.5V alkaline AA batteries
- Battery life : 4 years with an average of 200 operations per day
- Flat battery warning LED light on front sensor
- Built-in waterproof battery case



Product Details

Brand	DMP	Dimension	As Shown
Materials	Brass	Country of Origin	Italy
Finish	As Shown	WELS	Grade 1 (TM 17-0176)
		WSD Ref. No.	C20160659
		Expiry Date	17 April, 2021

* Information provided above is for reference only and is subject to change without prior notice.



Glory Top Building Materials Ltd
Glory Top Architectural Hardware Ltd
高晉建築材料有限公司
高晉五金建材有限公司

T | 3583 8333
E | Info@glorytop.com.hk
W | www.glorytop.com.hk
A | 15/F, 8 Jordan Road, Kowloon